

ROTOCLEAN Rubble Separator 149



Cimbria ROTOCLEAN type 149 is an efficient and rugged rubble separator for all types of grain and maize. The machine has a high capacity for pre-cleaning grains etc. with a high moisture and impurity content.

The unit is usually positioned at the intake point of a plant and requires only a minimum of supervision and maintenance.

The ROTOCLEAN is available in three sizes, viz. type 149.15, 149.20 and 149.25 with capacities from 75 to 150 tones grain per hour.

Design

The ROTOCLEAN is a totally enclosed, dustproof steel machine with all movable parts fully guarded.

The cleaning process is effected by means of three rotary drums ensuring an absolutely steady and vibrationless operation.

Function

The grain enters the inlet feeding over the full working width of the machine and runs on to three specially developed reels provided with "pockets" to accept the grain. Each reel is equipped with steel fingers, which carry larger impurities such as sticks, straw and stones into the waste outlet along with other large impurities, which will not drop into the pockets.

The grain from the pockets is then carried through to the air recirculating system.

The enclosed adjustable aspiration system draws across the full width of the machine all light particles such as chaff, shells and dust from the free falling grain. The coarse impurities are then deposited into the expansion chamber and discharged by means of a built-in screw conveyor. all light particles are removed through a slot across the full machine width and fed to the same outlet via a mini cyclone. 90% of the cleaned air from the aspiration system is recirculated.

Inlet

A steady and uniform flow of grain is imperative to obtain the optimum performance and cleaning quality. Therefore, it is strongly recommended to install a buffer bin with level indicator (as shown in the drawing). The buffer bin is available with the machine but must be specified on orders as a separate item.

Outlet

At the outlet a hopper for spout connection can be fitted (optional). Another possibility is to connect a chain conveyor directly to the outlet (optional). A hopper for the heavy waste is included and can be supplied with sack off arrangement or screw conveyor at extra cost. A sack off arrangement can also be supplied for the dust screw at extra equipment.

1. The inlet is equipped with a weighted flap, which together with the top reel ensures a uniform input flow. As extra equipment a level control is available which automatically starts and stops the feeding conveyor thus ensuring a steady supply.
2. The grain feed control is equipped with a spring-loaded counter weight releasing only when enough grain for filling up the machine has been supplied.
3. Baffle plates prevent kernels bouncing over the reels.
4. Steel fingers: Above each reel a set of steel fingers are installed in order to separate straws etc. from the grain. Above these 3 rows of steel fingers an air guiding plate is mounted, the plate controls the air volume that passes the steel fingers and hence the quantity of fine dust in the straw outlet.
5. Reels with "pockets": The 3 reels have different "pocket" sizes and numbers of revolutions. During rotation of the reels impurities bigger than the grain are being sorted out. The reels guide the grain to the aspiration system, where lighter particles are being sucked away due to their different flowing velocity.
6. Outlet across the full width of the machine for larger impurities, which have been mechanically separated from the grain. In this outlet will also be dust and light impurities together with

- some of the air pressure from the recirculating air system. A screw conveyor is available as extra equipment.
7. Discharge of cleaned grain: The pre-cleaned grain is discharged through an outlet across the full width of the machine. A hopper is available as extra equipment as is a sack off arrangement.
8. A cross-flow impellor re-circulates the air thus ensuring a uniform air velocity across the full width of the machine.
9. Re-circulating system: Specially developed plates guide the grain through the air flow to the outlet.
10. Air volume adjustment: in Order to obtain the optimum cleaning effect the air volume in the aspiration system must be regulated according to moisture content and impurity of the grain.
11. Dust collecting chamber: Dust and other light impurities are deposited in the dust collecting chamber and discharged by a screw conveyor (re. 13)
12. Mini cyclone: The dust is separated in the mini cyclone and collected in the screw conveyor (re. 13). Under normal conditions the cyclone can be connected to a central exhaust system.
13. The screw conveyor transports light particles from both the dust collecting chamber and the mini cyclone to the outlet is equipped with a control switch for overload which automatically stops the machine.

TYPE	149.15	149.20	149.25
Capacity per hour: Wheat % Barley (Max. 20% moisture)	70-80 t	app. 120 t	app. 150 t
Dimensions			
Height	2225 mm	2225 mm	2225 mm
Length	2200 mm	2200 mm	2200 mm
Width	2150 mm	2650 mm	3150 mm
Motors			
Rotary system (reels)	1.5 kW	1.5 kW	1.5 kW
Cross-flow fan	3 kW	4 kW	4 kW
Weight	1100 kg	1450 kg	1800 kg
Aspiration (sucked away from Mini cyclone pos. 12)	800 m ³ /H	1000 m ³ /H	1200 m ³ /H

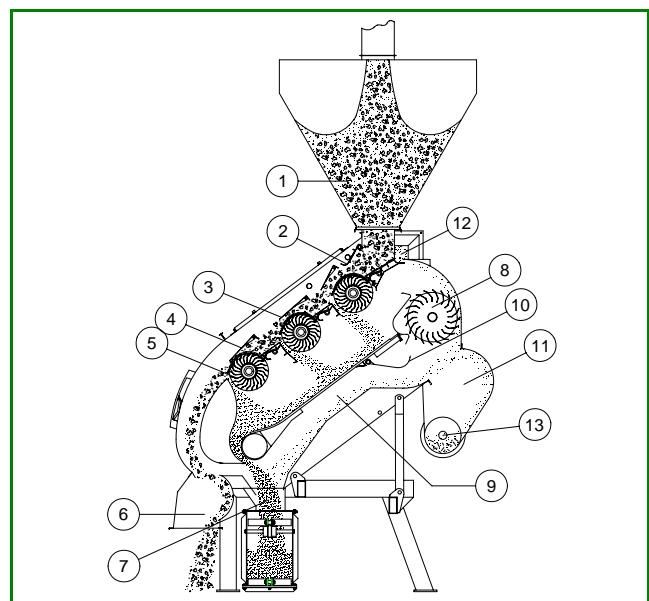

Copyright © - The right to alterations is reserved

